

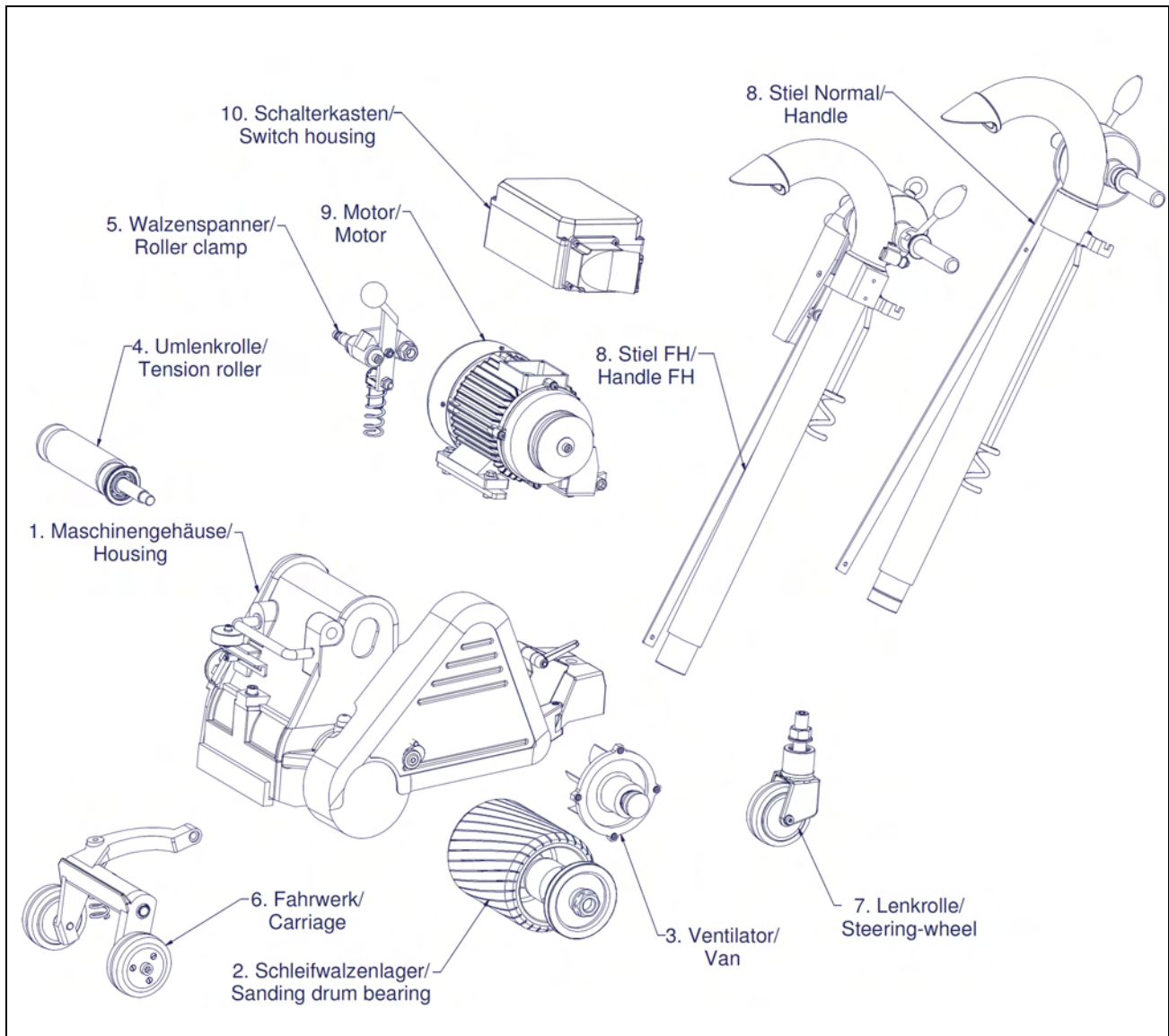

Ersatzteilliste / Spare parts list

Parkettschleifmaschine VIPER 1,85kW /50Hz,

Parquet sanding machine VIPER 1,85kW / 50Hz



Ersatzteilliste / Spare Part List # 078337



1. Maschinengehäuse / Housing

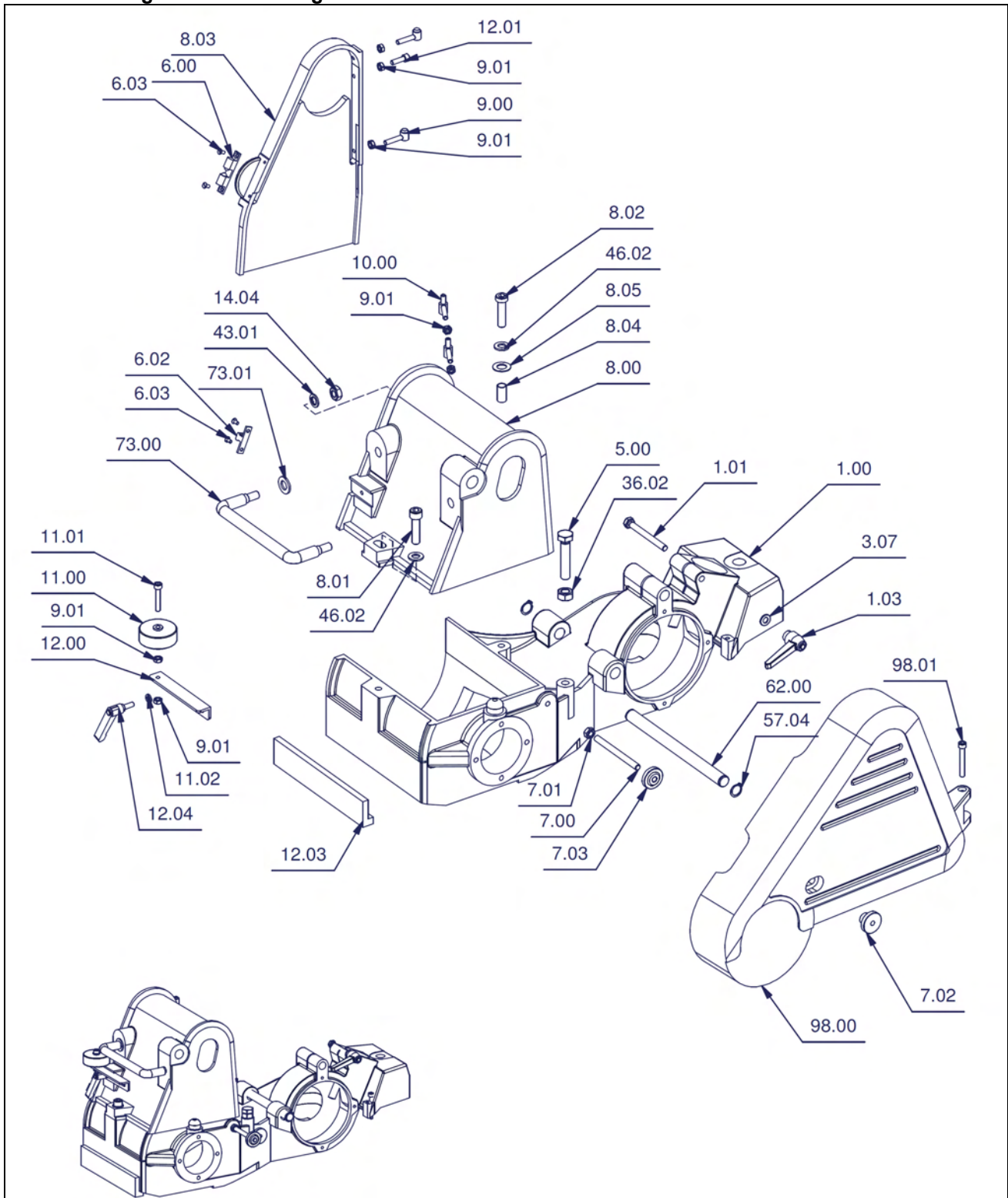



1. Maschinengehäuse / Housing

Pos	Pcs	#	Bezeichnung	Description	Norm
1.00	1	016461	Maschinenunterteil	Machine base	
1.01	1	018152	Sechskantschraube	Hexagon screw	DIN 933 - M8 x 80
1.03	1	014877	Klemmhebel verstellbar	Clamp lever	M8
3.07	1	014828	Scheibe	Washer	DIN 125-1 - B 8,4
5.00	1	016466	Sechskantschraube	Hexagon screw	DIN 933 - M12 x 60
6.00	1	016328	Deckel Schloss	Cover lock	
6.02	1	016384	Schloss Raste	Lock notch	
6.03	4	018323	Senkschraube	Counter sunk bolt	DIN 963 - M4 x 8
7.00	1	016330	Stiftschraube	Stud bolt	DIN 835 - M8 x 80
7.01	1	014810	Sechskantmutter	Hexagon nut	DIN 934 - M8
7.02	1	016331	Rändelmutter hoch	Knurled nut tall	DIN 466 - M8
7.03	1	018655	Rändelmutter niedrig	Knurled nut small	DIN 467 - M8
8.00	1	016475	Abdeckung	Covering	
8.01	1	042368	Zylinderschraube	Cylinder bolt	DIN 912 - M10 x 40
8.02	1	043912	Zylinderschraube	Cylinder bolt	DIN 6912 - M10 x 40
8.03	1	014603	Walzenschutzdeckel	Drum guard cover	
8.04	1	016478	Distanzbuchse	Spacer sleeve	12x10x22,5
8.05	1	043832	Federscheibe gewellt	Lock washer	DIN 137 - B12
9.00	2	016480	Deckelscharnier	Cover hinges	
9.01	7	014809	Sechskantmutter	Hexagon nut	DIN 934 - M6
10.00	2	016482	Haubenscharnier	Hood hinges	
11.00	1	016177	Anlaufgrad	Bumper wheel	
11.01	1	018264	Zylinderschraube	Cylinder bolt	DIN 912 - M6 x 35
11.02	1	014827	Scheibe	Washer	DIN 125 - A 6,4
12.00	1	016336	Winkel-Langlocheisen	Bumper wheel support	
12.01	1	014730	Zylinderschraube	Cylinder bolt	DIN 912 - M6 x 20
12.03	1	016490	Stossgummileiste	Rubber edge	
12.04	1	014212	Klemmhebel verstellbar	Clamp lever adjustable	GN300-45-M6x16
14.04	2	014811	Sechskantmutter	Hexagon nut	DIN 934 - M10
36.02	1	018663	Sechskantmutter	Hexagon nut	DIN 934 - M12
43.01	2	043831	Federring	Circlip	DIN 128 - A10
46.02	2	014829	Unterlegscheibe	Flat washer	DIN 125 - A 10,5
57.04	2	018101	Sicherungsring	Circlip	DIN 471 - 15x1
62.00	1	016556	Fahrwerkachse	Main axle	
73.00	1	016564	Tragegriff	Carry handle	
73.01	1	016565	Scheibe	Washer	DIN 125 - A 13
98.00	1	016567	Riemenschutzhaube	Belt guard	
98.01	1	017659	Zylinderschraube	Cylinder bolt	DIN 912 - M6 x 45



2. Schleifwalzenlager / Sanding Drum Bearing

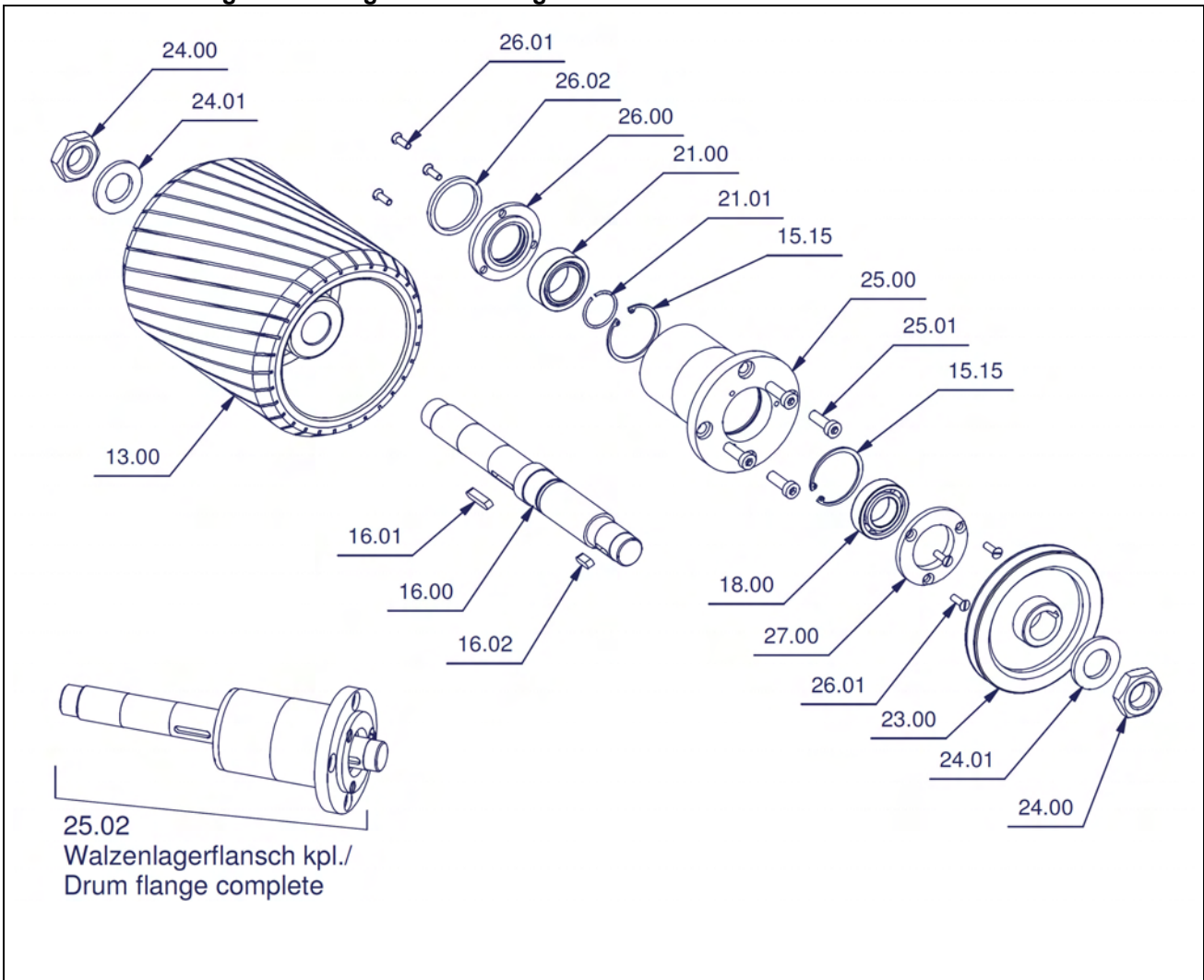

25.02
Walzenlagerflansch kpl./
Drum flange complete

Pos	Pcs	#	Bezeichnung	Description	Norm
13.00	1	014201	Schleifwalze	Sanding drum	
15.15	2	014855	Sicherungsring	Circlip	DIN 472 - 47x1,75
16.00	1	014608	Schleifwalzenwelle	Drum shaft	
16.01	1	016361	Paßfeder	Parallel key	DIN 6885 - A 6 x 6 x 30
16.02	1	016505	Paßfeder	Parallel key	DIN 6885 - A 6 x 6 x 16
18.00	1	014704	Rillenkugellager	Ball bearings	DIN 625 T1-6005-25x47x12
21.00	1	014611	Nadellager	Needle bearing	DIN 617 - NA 4906
21.01	1	043868	Sprengring	Safety Washer	DIN 7993 - A 30
23.00	1	014613	Walzenriemenscheibe	Drum pulley	
24.00	2	014614	Sechskantmutter	Hexagon nut	DIN 936 - M24x1,5
24.01	2	018226	Scheibe	Washer	DIN 125 - A 25
25.00	1	016507	Walzenlagerflansch	Drum bearing flange	
25.01	4	016365	Zylinderschraube	Cylinder bolt	DIN 6912 - M8 x 25
25.02	1	048673	Walzenlagerflansch kpl.	Drum flange complete	
26.00	1	016509	Lagerdeckel innen	Inner drum cover	
26.01	6	016701	Senkschraube	Counter sunk bolt	DIN 963 - M5 x 16
26.02	1	016188	Filzdichtring	Felt packing strip	
27.00	1	016511	Lagerdeckel aussen	Outer drum cover	



3. Ventilator / Van

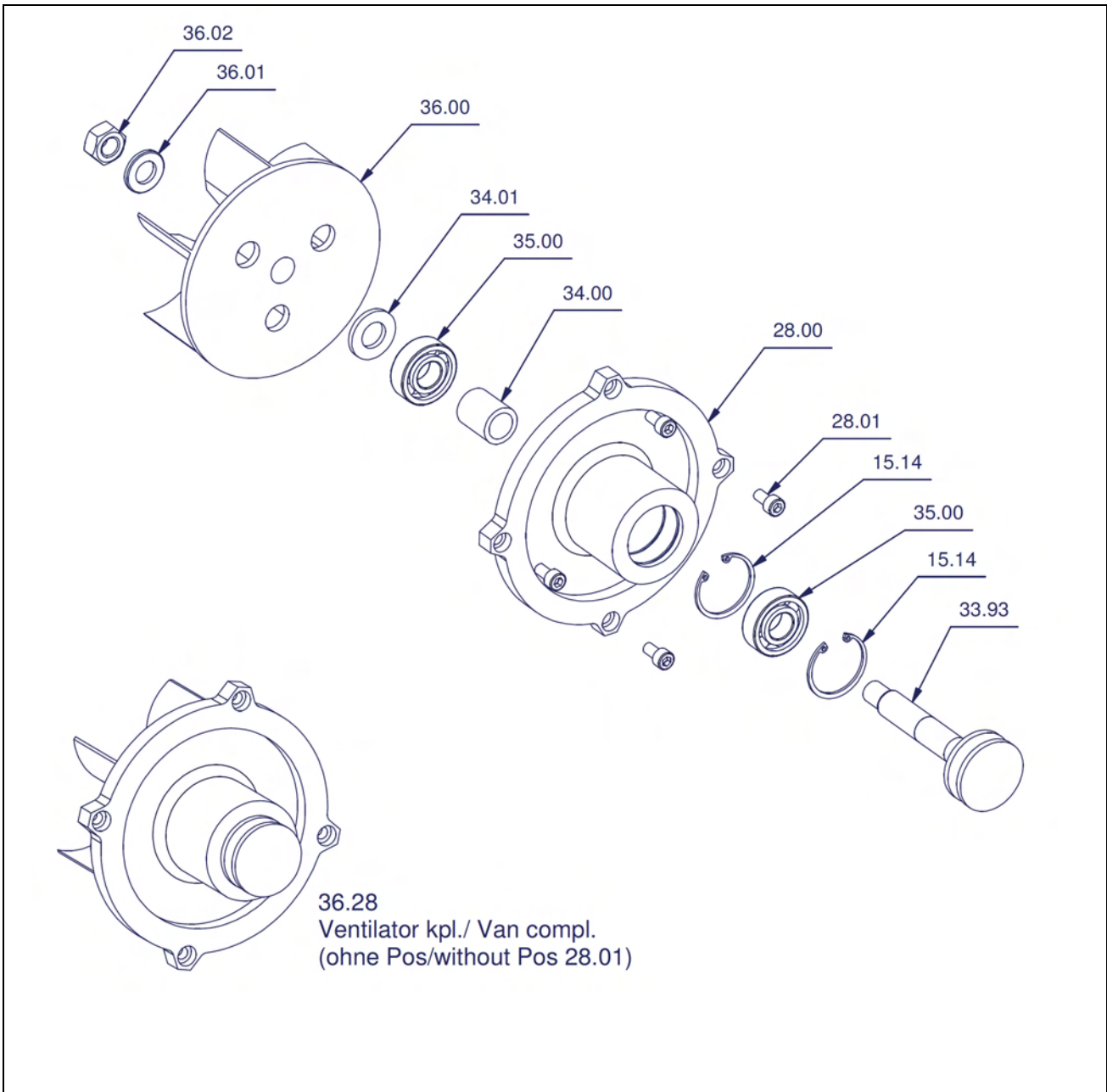

36.28 Ventilator kpl./ Van compl. (ohne Pos/without Pos 28.01)

Pos	Pcs	#	Bezeichnung	Description	Norm
15.14	2	018091	Sicherungsring	Circlip	DIN 472 - 35x1,5
28.00	1	016513	Ventilatorflansch	Fan flange	
28.01	4	014726	Zylinderschraube	Cylinder bolt	DIN 912 - M6 x 12
33.93	1	014616	Ventilatorwelle	Fan Shaft	
34.00	1	016514	Distanzbuchse	Spacer	
34.01	1	043878	Scheibe	Washer	DIN 134 - 15 x 3
35.00	2	018351	Rillenkugellager	Ball bearing	DIN 625 T1-6202-15x35x11
36.00	1	014618	Ventilatorrad	Fan	
36.01	1	014830	Scheibe	Washer	DIN 125-1 - B 13
36.02	1	018663	Sechskantmutter	Hexagon nut	DIN 934 - M12
36.28	1	048674	Ventilator kompl.	Van compl.	



4. Umlenkrolle / Tension Roller

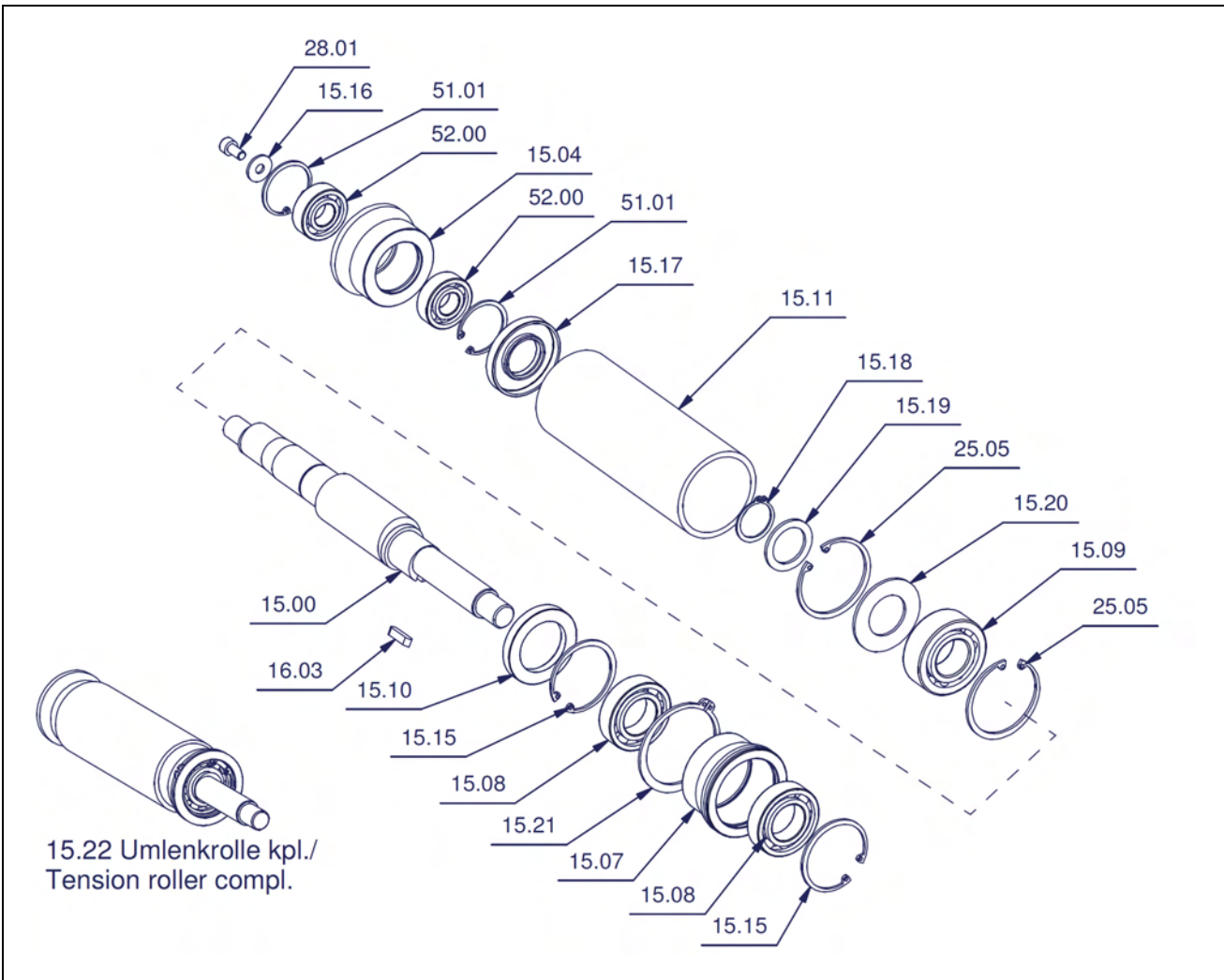

Pos	Pcs	#	Bezeichnung	Description	Werkstoff/Norm
15.00	1	014619	Umlenkrollenwelle	Tension roller shaft	
15.04	1	014622	Aussenrolle	External roller	
15.07	1	014625	Innenrolle	Inner roll empty	
15.08	2	014704	Rillenkugellager	Ball bearing	DIN 625 T1 - 6005-25x47x12
15.09	1	016198	Pendelkugellager	Swivel bearing	DIN 630 - 2205 - 25x 52x15
15.10	1	014628	Wellendichtring	Shaft sealing ring	DIN 3760-AS-25x35x7-NBR
15.11	1	014629	Laufrolle leer	Roller	
15.15	2	014855	Sicherungsring	Circlip	DIN 472 - 47x1,75
15.16	1	017724	Scheibe	Washer	DIN 9021 - 6,4
15.17	1	014634	Wellendichtring	Shaft sealing ring	DIN 3760-AS-25x52x7-NBR
15.18	1	014852	Sicherungsring	Circlip	DIN 471 - 25x1,2
15.19	1	016360	Passscheibe	Compens. washer	Sonder. 25x30x2
15.20	1	043833	Federscheibe gewellt	Spring washer	51x42x0,5
15.21	1	043894	Sicherungsring	Circlip	DIN 471 - 60x2
15.22	1	016844	Umlenkrolle kpl.	Tension roller compl.	
16.03	1	043861	Paßfeder	Feather key	DIN 6885 - A 5 x 5 x 20
25.05	2	014857	Sicherungsring	Circlip	DIN 472 - 52x2
28.01	1	014726	Zylinderschraube	Cylinder screw	DIN 912 - M6 x 12
51.01	2	018091	Sicherungsring	Circlip	DIN 472 - 35x1,5
52.00	2	018351	Rillenkugellager	Ball bearing	DIN 625 T1-6202-15x35x11



5. Walzenspanner / Roller clamp

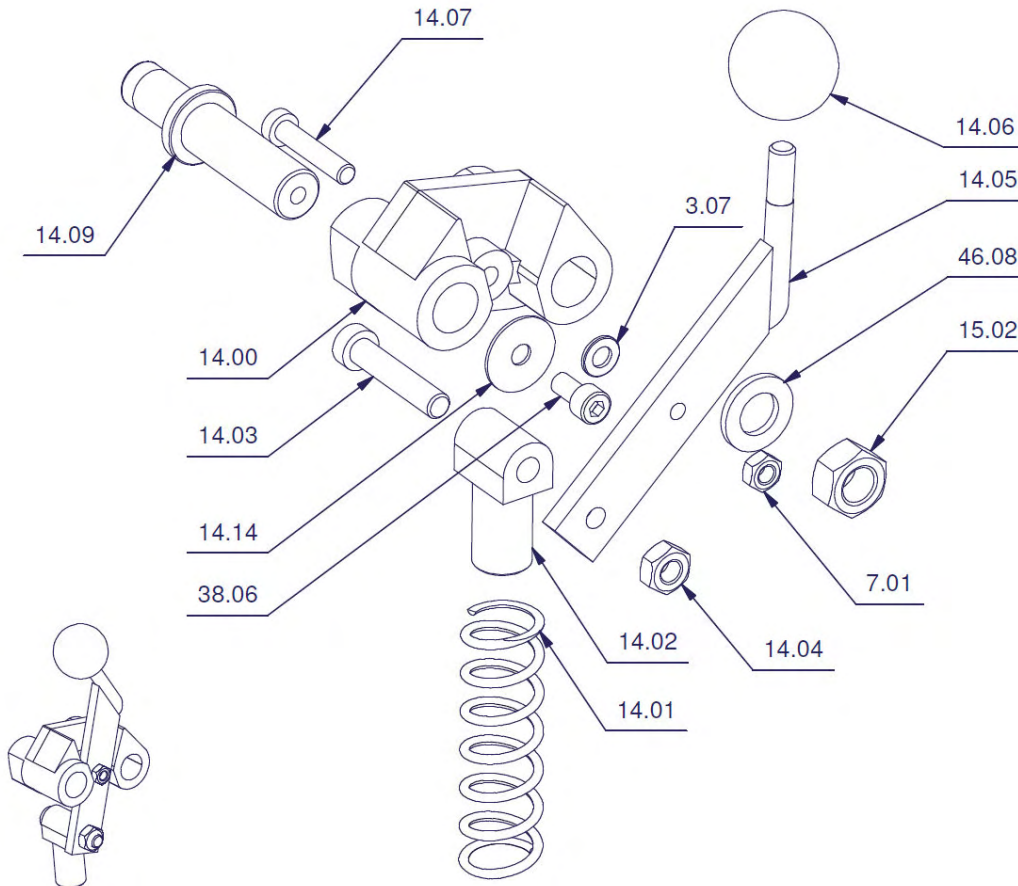

14.41 Spannwalzenhalter kpl./
Roller clamp compl.

Pos	Pcs	#	Bezeichnung	Description	Werkstoff/Norm
7.01	4	014810	Unterlegscheibe	Flat washer	DIN 934 - M8
14.00	1	016338	Sechskantmutter	Hexagon nut	
14.01	1	016179	Spannwalzenhalter	Tension lever	
14.02	1	016492	Druckfeder	Pressure spring	
14.03	1	016340	Druckstück	Pressure pad	DIN 6912 - M10 x 50
14.04	1	014811	Zylinderschraube	Cylinder bolt	DIN 934 - M10
14.05	1	016342	Sechskantmutter	Hexagon nut	
14.06	1	016180	Spannhebel	Tension lever	
14.07	1	016343	Kugelknopf	Button	DIN 6912 - M8 x 45
14.09	1	016345	Zylinderschraube	Cylinder bolt	
14.10	1	017116	Haltebolzen	Mounting bolt	DIN 963 - M8 x 30
14.11	1	016347	U-Scheibe	Flat washer	DIN 444 - A - M8 x 80
14.14	1	043902	Spannwalzenhalter kompl	Tension lever compl.	DIN 522 - 8,4 x 30
14.15	1	048500	Sechskantmutter	Hexagon nut	
15.01	1	016190	Zylinderschraube	Cylinder bolt	
15.02	1	014620	Scheibe	Washer	DIN 934 - M16



6.Fahrwerk / Carriage

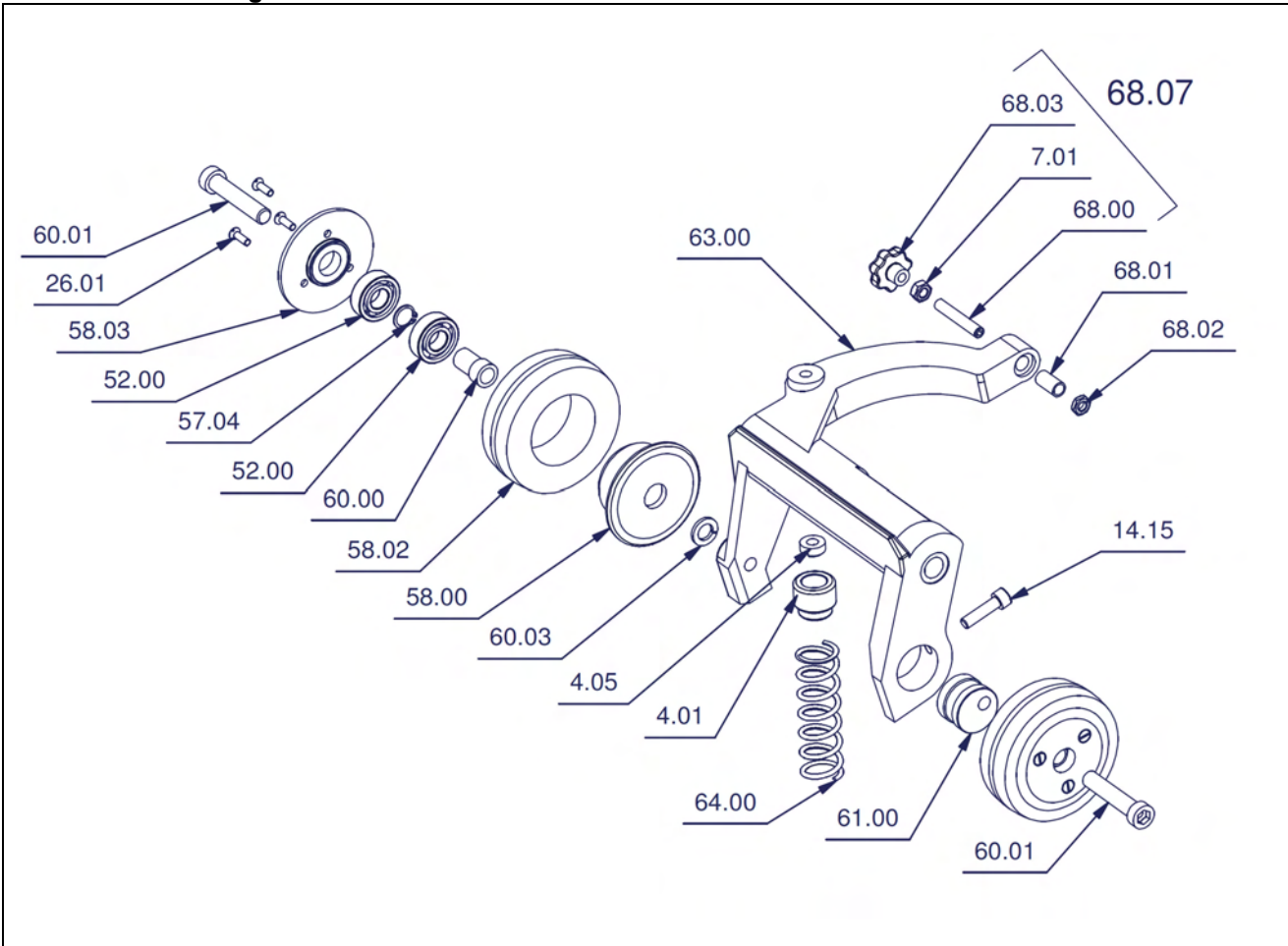

Pos	Pcs	#	Bezeichnung	Description	Werkstoff/Norm
4.01	1	047077	Federdruckplatte normal	Spring pressureplate	
4.01	1	016465	Federdruckplatte FH	Spring pressureplate	
4.05	1	043881	Sechskantmutter	Hexagon nut	DIN14441 - M10
7.01	1	014810	Sechskantmutter	Hexagon nut	DIN 934 - M8
14.15	1	014736	Zylinderschraube	Cylinder bolt	DIN 912 - M8 x 30
26.01	6	016701	Senkschraube	Counter sunk bolt	DIN 963 - M5 x 16
52.00	4	018351	Rillenkugellager	ball bearing	DIN 625 T1-6202-15x35x11
57.04	2	018101	Sicherungsring	Circlip	DIN 471 - 15x1
58.00	2	016415	Lauf- u. Lenkradfelge	Caster wheel felloe	
58.02	2	016171	Vulkolanbelag	Vulkolan-shoe	
58.03	2	016416	Felgendeckel	Felloe cover	
60.00	2	016422	Laufradbuchse	Running wheel bushing	
60.01	2	016554	Zylinderschraube	Cylinder bolt	DIN 6912 - M12 x 55
60.03	1	016424	Federring	Springwasher	DIN 127 - A 12
61.00	1	016425	Exzenter	Excentric	
63.00	1	016558	Fahrwerkhebel	Running wheel bracket	
64.00	1	014554	Druckfeder	Tension spring	
68.00	1	017522	Gewindestift	Headless pin	DIN 913 - M8 x 50
68.01	1	016561	Distanzbuchse	Spacer	
68.02	1	017676	Sechskantmuttern	Hexagon nut	DIN 936 - M8
68.03	1	016563	Sterngriffmutter	Star grip nut	M8
68.07	1	043898	Sterngriffschraube m. Kontermutter	Star grip screw and nut	



7. Lenkrolle / Steering Wheel

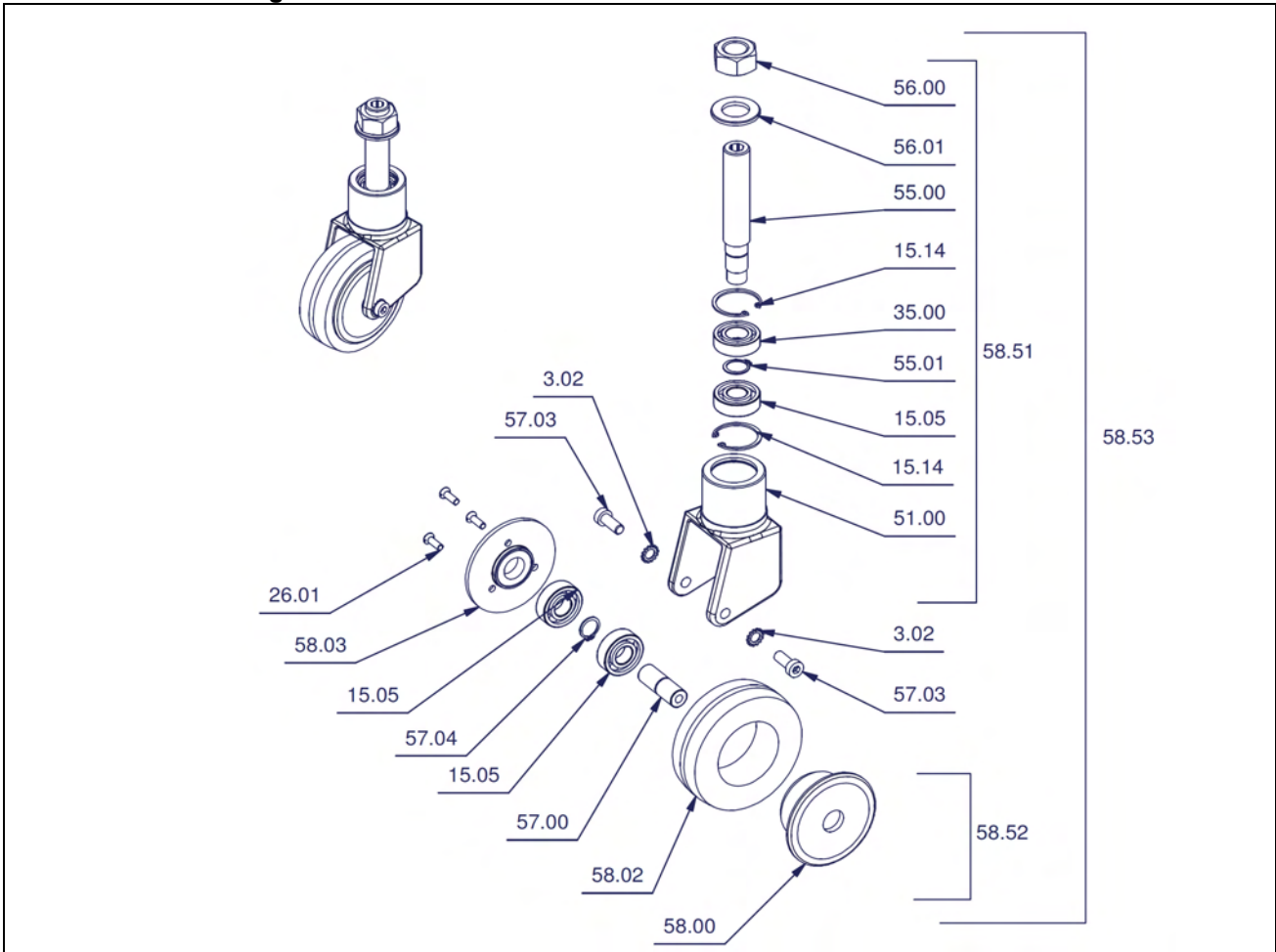

Pos	Pcs	#	Bezeichnung	Description	Norm
3.02	2	016321	Fächerscheibe	Serrated lock washer	DIN 6798 - A 8,4
15.05	3	018351	Rillenkugellager	Ball bearing	DIN 625 T1-6202- 15x35x11
15.14	2	018091	Sicherungsring	Circlip	DIN 472 - 35 x 1,5
26.01	3	016701	Senkschraube	Counter sunk bolt	DIN 963 - M5 x 16
35.00	1	018359	Rillenkugellager	Ball bearings	DIN 625 T1 -6003-17x35x10
51.00	1	016406	Lenkradgabel	Steering-wheel fork	
55.00	1	016539	Schwenkachse	Bushing axle	
55.01	1	014850	Sicherungsring	Circlip	DIN 471 - 17 x 1
56.00	1	039981	Sechskantmutter	Hexagon nut	DIN 934 - M20
56.01	1	039982	Scheibe	Washer	DIN 125-1 - B 21
57.00	1	014601	Lenkrad-Achse	Caster wheel axle	
57.03	2	016413	Zylinderschraube	Cylinder bolt	DIN 6912 - M8 x 20
57.04	1	018101	Sicherungsring	Circlip	DIN 471 - 15 x 1
58.00	1	016415	Lauf- u. Lenkradfelge	Caster wheel fell.	
58.02	1	016171	Vulkolanbelag	Vulkollan-shoe	
58.03	1	016416	Felgendeckel	Felloe cover	
58.51	1	048678	Lenkradgabel kompl. ohne Rad	Steering-wheel fork compl.without wheel	
58.52	1	048583	Lenkrad kompl.	Steering-wheel compl.	
58.53	1	047062	Lenkradgabel kompl. mit Rad	Steering-wheel fork compl. with wheel	



8. Stiel komplett / Handle complete

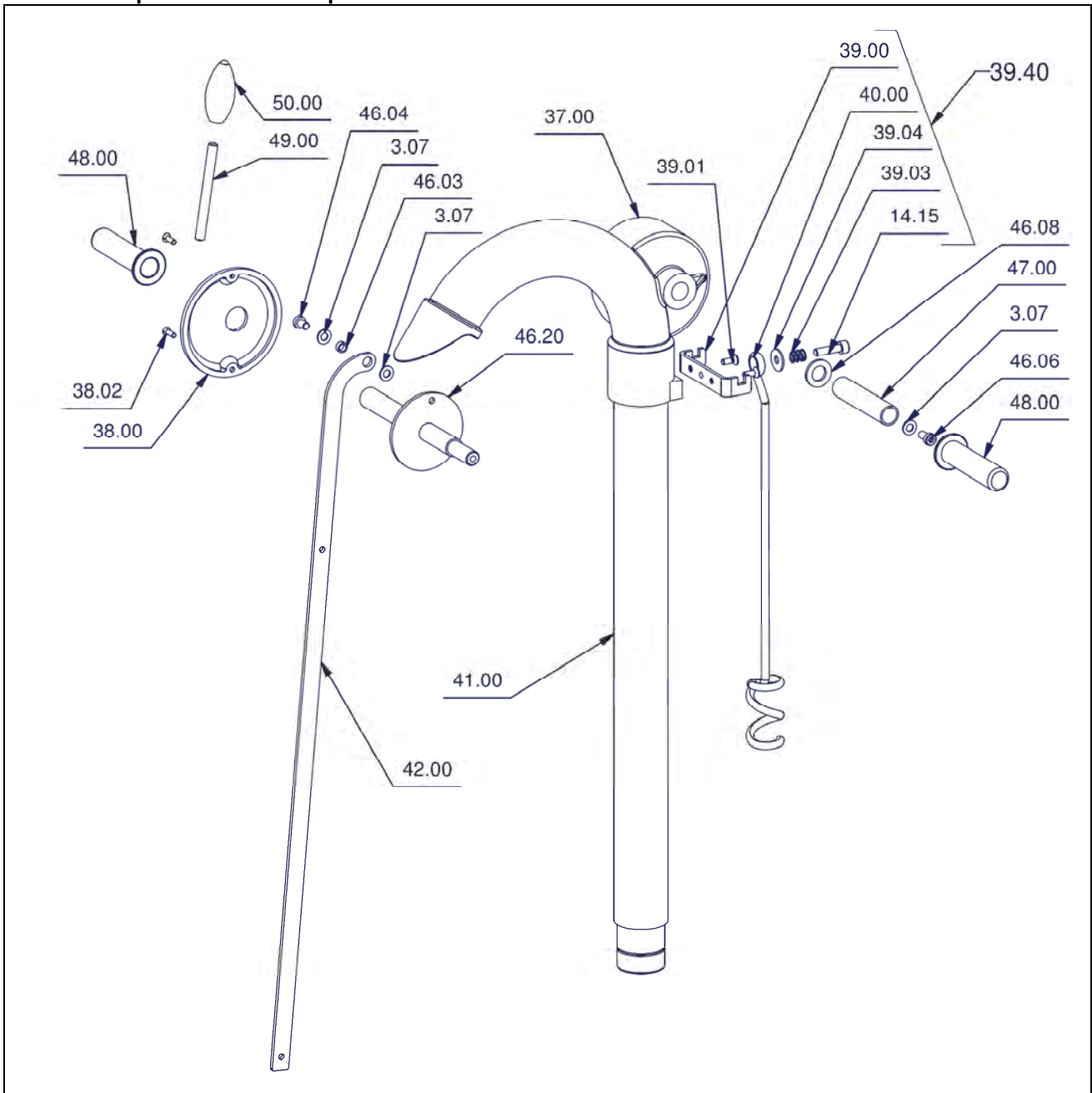



8. Stiel komplett / Handle complete

Pos	Pcs	#	Bezeichnung	Description	Norm
3.07	3	014828	Unterlegscheibe	Washer	DIN 125 - A 8,4
3.08	1	049187	Stiel kompl.	Handle compl.	
14.15	1	014736	Zylinderschraube	Cylinder bolt	DIN 912 - M8 x 30
37.00	1	016387	Lenkerkopfgehäuse	Steering head cover	
38.00	1	016388	Gehäusedeckel	Steering head cover	
38.02	2	016701	Senkschraube	Counter sunk bolt	DIN 963 - M5 x 16
39.00	1	016521	Kabelhalterstütze	Pier for cable clip	
39.01	2	014756	Senkschraube	Counter sunk bolt	DIN 7991 - M6 x 16
39.03	1	043827	Druckfeder	Pressure spring	
39.04	1	018737	Unterlegscheibe	Washer	DIN 9021 - 8,4
39.40	1	048582	Kabelhalterarm kompl.	Cable bracket compl.	
40.00	1	014548	Kabelhalterarm	Cable arm	
41.00	1	016525	Staubrohr	Dust pipe	
42.00	1	016526	Zugstange normal	Contr. rod	
46.03	1	016437	Distanzbuchse	Spacer	
46.04	1	016397	Zylinderschraube	Cylinder bolt	DIN 6912 - M8 x 12
46.06	1	017651	Zylinderschraube	Cylinder bolt	DIN 6912 - M8 x 16
46.08	1	014831	Unterlegscheibe	Washer	DIN 125 - A 17
46.20	1	016279	Handgriffhalter re.	Grip fixation	
47.00	1	016280	Handgriff links	Grip	
48.00	2	014549	Handgriff	Grip	
49.00	1	016404	Hebelbolzen	Bolt	
50.00	1	016180	Ballengriff	Handle grip	



8. Stiel FH komplett / Handle FH complete

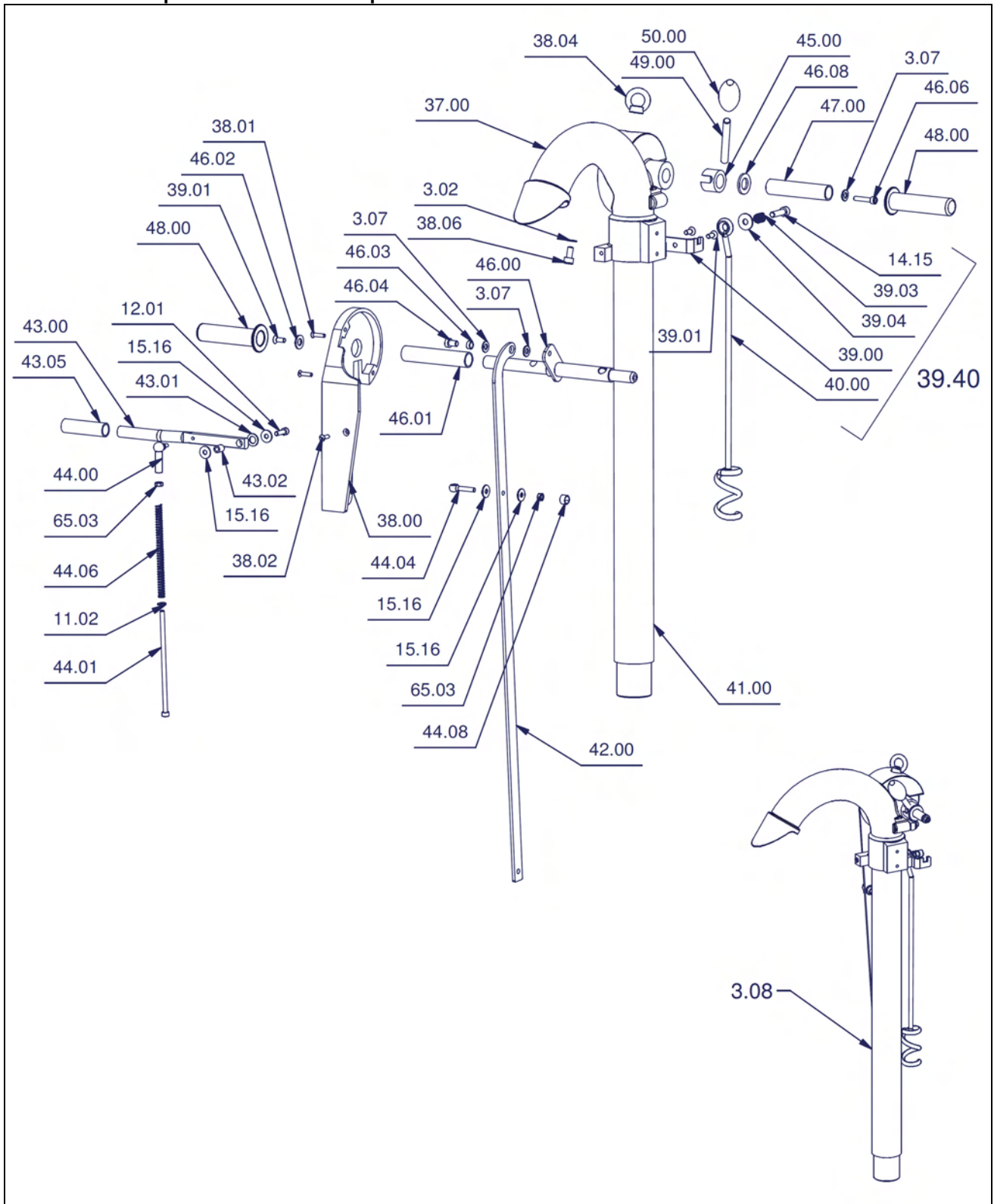



8. Stiel FH komplett / Handle FH complete

Pos	Pcs	#	Bezeichnung	Description	Norm
3.02	1	016321	Fächerscheibe	Serrated lock washer	DIN 6798 - A 8,4
3.07	3	014828	Scheibe	Washer	DIN 125-1 - B 8,4
3.08	1	048679	Stiel FH kompl.	Handle FH compl.	DIN 125-1 - B 8,4
11.02	1	014827	Scheibe	Washer	DIN 125 - A 6,4
12.01	1	014730	Zylinderschraube	Cylinder bolt	DIN 912 - M6 x 20
14.15	1	014736	Zylinderschraube	Cylinder bolt	DIN 912 - M8 x 30
15.16	4	017724	Scheibe	Washer	DIN 9021 - 6,4
37.00	1	016614	Lenkerkopfgehäuse	Steering head cage	
38.00	1	016615	Gehäuseabdeckung	Steering head cover	
38.01	2	016386	Senkschraube	Counter sunk bolt	DIN 963 - M5 x 20
38.02	1	016701	Senkschraube	Counter sunk bolt	DIN 963 - M5 x 16
38.04	1	016618	Ringmuttern	Ring nut	DIN 582 - M8
38.06	1	017116	Zylinderschraube	Cylinder bolt	DIN 912 - M8 x 16
39.00	1	016521	Kabelhalterstütze	Pier for cable clip	
39.01	3	014756	Senkschraube	Counter sunk bolt	DIN 7991 - M6 x 16
39.03	1	043827	Druckfeder	Pressure spring	
39.04	1	018737	Scheibe	Washer	DIN 9021 - 8,4
39.40	1	048582	Kabelhalter kompl.	Cable bracket compl.	
40.00	1	014548	Kabelhalterarm	Cable arm	
41.00	1	016525	Staubrohr (690)	Dust pipe (690)	
42.00	1	016526	Zugstange normal	Contr. rod	
43.00	1	016628	Abhebewinkel	Drum lifting angle	
43.01	1	043831	Federring	Spring washer	DIN 128 - A10
43.02	1	016629	Distanzbuchse	Spacer	10 x 6 x 12,4
43.05	1	043838	Schrumpfschlauch	Shrinking hose	
44.00	1	016632	Gelenkstück	Hinge	
44.01	1	016673	Zylinderschraube	Cylinder bolt	DIN 912 - M6 x 150
44.04	1	016635	Ringschraube	Eye bolt	DIN 444 - A - M6 x 35
44.06	1	016638	Druckfeder	Pressure spring	
44.08	1	043882	Abdeckung f. Sechskant	Cover nut	
45.00	1	016640	Druckbuchse	Spacer	
46.00	1	016641	Handgriff re. FH	Grip	
46.01	1	016642	Handgriff Rohr	Grip tube	
46.02	1	014829	Scheibe	Washer	DIN 125 - A 10,5
46.03	1	016437	Distanzbuchse	Spacer	11 x 8 x 5
46.04	1	016397	Zylinderschraube	Cylinder bolt	DIN 6912 - M8 x 12
46.06	1	017678	Zylinderschraube	Cylinder bolt	DIN 912 - M6 x 30
46.08	1	014831	Scheibe	Washer	DIN 125 - A 17
47.00	1	016280	Handgriff links	Grip left	
48.00	2	014549	Handgriff	Grip	
49.00	1	016404	Hebelbolzen	Bolt	
50.00	1	016180	Ballengriff	Handle grip	
65.03	2	014809	Sechskantmutter	Hexagon nut	DIN 934 - M6



9. Motor /Motor

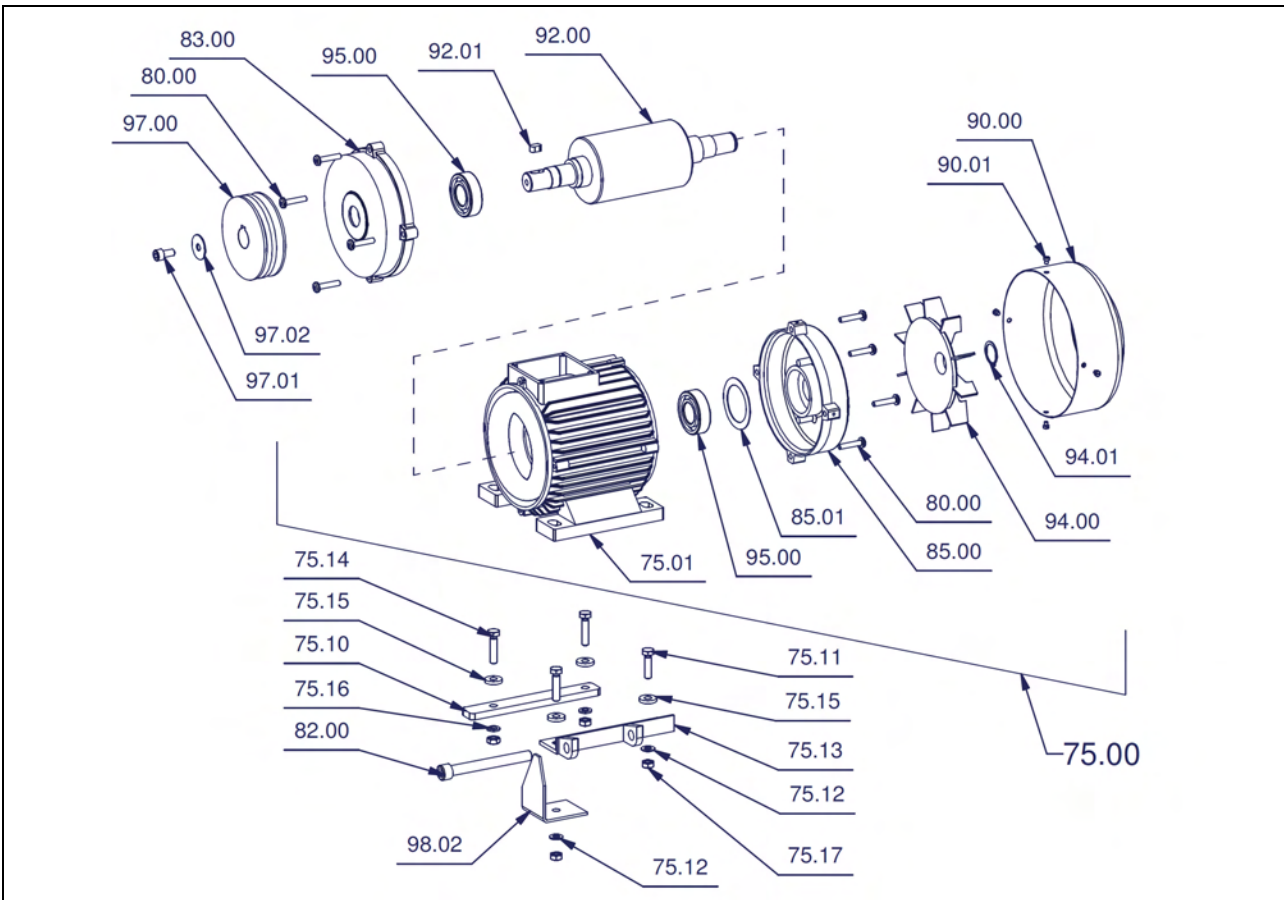

Pos	Pcs	#	Bezeichnung	Description	Norm
75.00	1	048648	Motor kompl.	Motor compl.	
75.01	1	043895	Motorgehäuse m. Stator	Chassis Motor	
75.10	1	016570	Sockeleisen vorn	Base iron	
75.11	1	017060	Sechskantschraube	Hexagon bolt	DIN 933 - M8 x 30
75.12	2	014828	Unterlegscheibe	Washer	DIN 125-1 - B 8,4
75.13	1	016571	Motorsockel	Motor base	
75.14	3	018158	Sechskantschraube	Hexagon bolt	DIN 933 - M8 x 35
75.15	4	018240	Scheibe	Washer	DIN 7349 - 8,4
75.16	2	016455	Federring	Spring washer	DIN 127 - A 8
75.17	4	014810	Sechskantmutter	Hexagon nut	DIN 934 - M8
80.00	8	043836	Gewindefurchende Schraube	Winding bolt	DIN 7500 - M6 x 30
82.00	1	043921	Zylinderschraube	Cylinder-head bolt	DIN 912 - M12 x 100
83.00	1	043908	Vorderes Lagerschild	Front bearing cover	
85.00	1	043839	hinteres Lagerschild	Rear bearing cover	
85.01	1	043912	Wellenring	Ring	
90.00	1	043905	Ventilatorhaube	Fan cover	
90.01	4	043919	Zylinderschraube	Cylinder bolt	DIN 84 - M4 x 4
92.00	1	043866	Rotor	Rotor	
92.01	1	043862	Passfeder	Drum parallel key	DIN 6885 - 8x7x14
94.00	1	043859	Motorventilator	Motor fan	
94.01	1	043892	Sicherungsring	Circlip	DIN 471 - 24x1,2
95.00	2	018348	Kugellager, einreihig	Ball bearing	DIN 625 - 6205 - 25x 52x15
97.00	1	014547	Motorriemenscheibe	Motor pulley	
97.01	1	018251	Zylinderschraube	Cylinder bolt	DIN 6912 - M8 x 16
97.02	1	043902	U-Scheibe	Washer	DIN 522 - 8,4 x 30
98.02	1	043883	Schutzblech	Protection plate	



10. Schalterkasten / Switch Housing

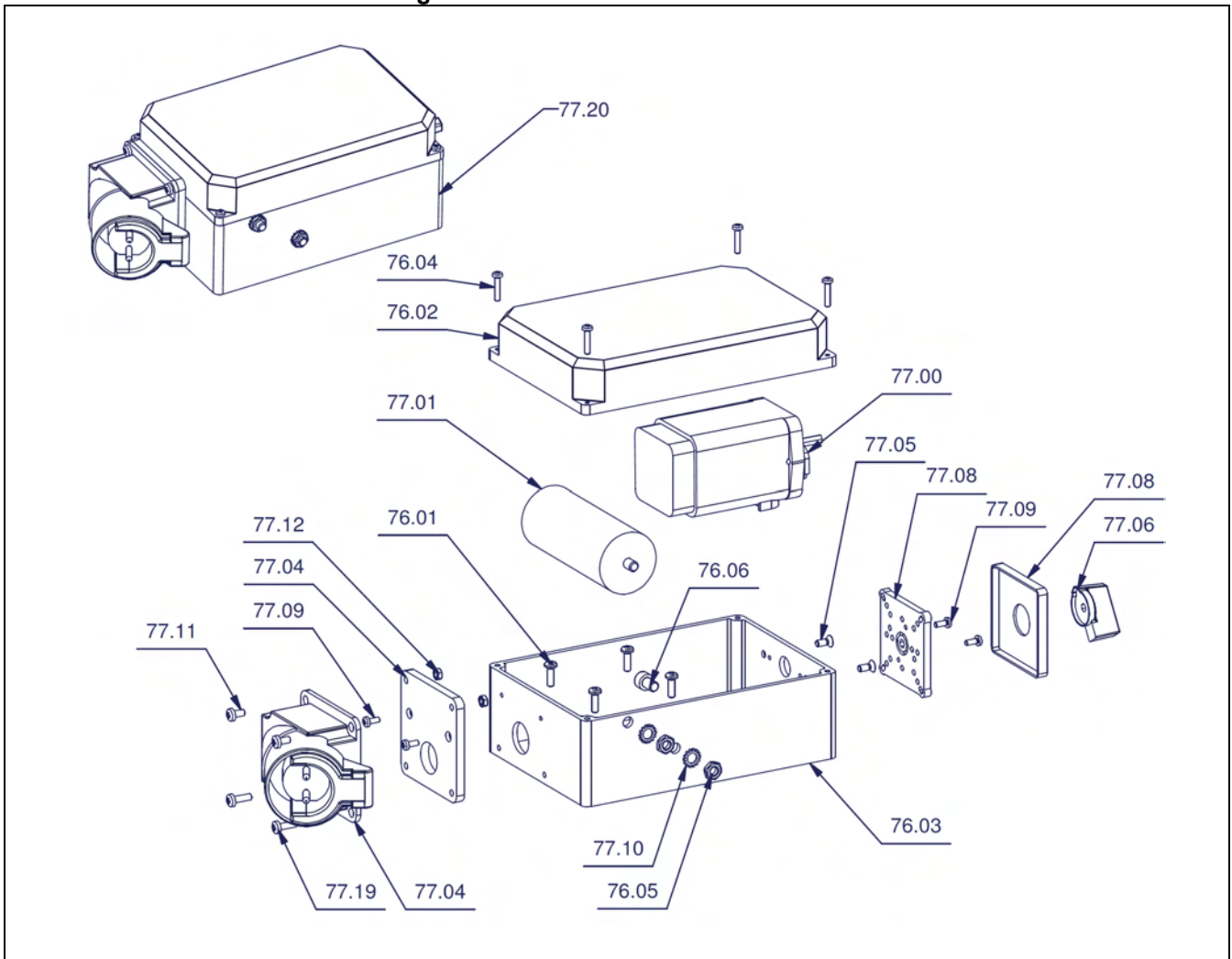

Pos	Pcs	#	Bezeichnung	Description	Norm
76.01	4	049052	Gewindefurchende Schraube	Winding bolt	DIN 7500 - M5 x 16 - 4.8 - Z
76.02	1	043872	Schalterkasten Deckel	Switch housing cover	
76.03	1	043874	Schalterkasten Gehäuse	Switch housing housing	
76.04	4	014805	Linsenschraube	Raised-head bolt	DIN 7985 (H) - M4x20-H
76.05	2	017676	Sechskantmuttern	Hexagon nut	DIN 936 - M8
76.06	1	018254	Zylinderkopfschraube	Cylinder-head bolt	DIN 912 - M8 x 12
77.00	1	043870	Schaltereinsatz 50Hz	Switcher	
77.01	1	043843	Kondensator 60 µF	Condensator 60 µF	
77.04	1	048551	Wandgerätestecker	Connector	
77.05	2	043890	Senkschraube	Counter sunk bolt	DIN 965 - M5 x 12
77.06	1	043875	Schalterknebel	Switch toggle	
77.08	1	043877	BG Schalterpositionsschild	Position label	
77.09	4	043851	Linsenschrauben	Raised-head bolt	DIN 7985 - M4x10
77.10	2	016321	Fächerscheibe	Serrated lock washer	DIN 6798 - A 8,4
77.11	2	017681	Linsenschraube	Raised-head bolt	DIN 7985 (H) - M5x10-H
77.12	2	017773	Sechskantmutter	Hexagon nut	DIN 934 - M5
77.19	2	048507	Linsenschraube	Raised-head bolt	DIN 7985 (H) - M5x16-H
77.20	1	048680	Schalterkasten Kompl.	Switch housing compl.	



Schalterstellung

0 Aus Stop

1 Anlauf Start

2 Betrieb

Schalter Switch

Motor

Hilfsphase

OV = Überlastungsschutz = Overload - Switch
 ZV = Nullspannungsauslöser = Zero - Voltage - Stop - Switch
 MS = Haupt - Schalter = Main - Switch
 Fällt ab bei Spannungsausfall an "CV" oder "ZV"
 C₀ = Kondensator - Motoren / Capacitor - Motors

Pos	#	Description	Bezeichnung
1	013839	Staubsack	dust bag
2	016813	Multiclip	Multiclip
3	016732	Atemschutzmaske	respirator
4	015315	Gehörschutz	hearing protectors
5	016569	Werkzeugtasche, leer	tool pouch, empty
6	014956	Inbusschlüssel 5 mm	socket wrench 5 mm
7	014957	Inbusschlüssel 6 mm	socket wrench 6 mm
8	014959	Inbusschlüssel 8 mm	socket wrench 8 mm
9	018641	Inbusschlüssel 10 mm	socket wrench 10 mm
10	016842	Gabelschlüssel 10 mm	fork wrench 10 mm
11	016800	Gabelschlüssel 19 mm	fork wrench 19 mm
12	018635	Gabelschlüssel 24 mm	fork wrench 24 mm
13	043826	Doppelgabelschlüssel 30/36 mm	double fork wrench 30/36 mm
14	047382	Netzkabel komplett	Cable compl.
15	050871	Bedienungsanleitung	operating instructions
16	040383	Rad-Einstellhilfe	running wheel adjusting tool
17	048682	Werkzeugset komplett	Tool kit complete
	014556	Walzen Keilriemen XPZ 862	drum V-belt XPZ 862
	014557	Ventilator Keilriemen 8 x 600	fan V-belt 8 x 600